

# SERVICE MANUAL

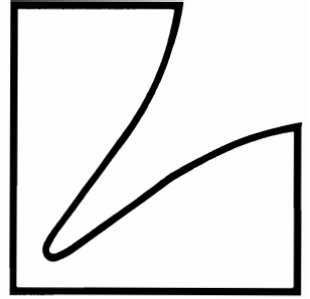

## Compact Disc Player **D-102**



# Contents

Specifications . . . . .	2
Before Use . . . . .	2
Parts Locations and Disassembly Instructions . . . . .	3 to 5
Adjustment Locations . . . . .	6
Adjustment Procedures . . . . .	6 to 7
Block Diagram . . . . .	8
Schematic Diagram . . . . .	9 to 11
Parts Layout on P.C. Boards and Wiring Diagram . . . . .	12 to 14
Electrical Parts List . . . . .	15 to 19
Cabinet Assembly Parts List . . . . .	20
Exploded View (Cabinet) . . . . .	21 to 22
Exploded View (Mechanism) . . . . .	23 to 24
Mechanism Assembly Parts List . . . . .	25
Packing Assembly Parts List . . . . .	26
Packing Method View . . . . .	26
Semi-Conductor Lead Identifications . . . . .	27 to 31

## Specifications

Type . . . . .	Compact Disc player with optical pickup
Quantization . . . . .	16 bit linear
Channels . . . . .	2 channels (Stereo)
Frequency Response . . . . .	20 Hz – 20 kHz ±0.5 dB
Dynamic Range . . . . .	Over 90 dB
Total Harmonic Distortion . . . . .	0.005% (1 kHz)
Channel Separation . . . . .	Over 36 dB
Wow and Flutter . . . . .	Unmeasurable
Output . . . . .	2 Volts
Pickup . . . . .	Semiconductor laser
Track Search . . . . .	By track number
Power Supply . . . . .	120V, 60 Hz (UC/UQ) 220V, 50 Hz (EK)
Power Consumption . . . . .	14 Watts
Dimensions . . . . .	438(W) x 82(H) x 309(D) mm
Weight . . . . .	4.4 kg
Accessories . . . . .	Connection cables (Pin plugs) x 1 Remote control unit x 1 AC Cord x 1 (EK)

Due to product improvement, designs and specifications are subject to change.

## Before Use

1. Remove two transport screws (Red) (Turn 5 or 6 rounds.) until they are fully released (The screws can not be taken away out).
2. Release the transport lock by turning counterclockwise until it stops. (It turn half a turn.)

**Note:** When transporting the unit, take a disc away and close the disc tray by pressing the Open/Close button. Turn the Power off and fasten with transport screws and lock.

When transfer screws and lock are fastened, normal operations are not available.

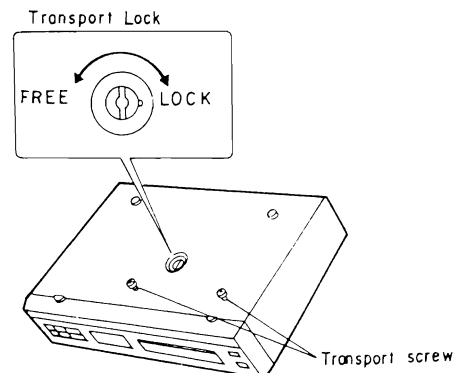

# Parts Locations and Disassembly Instructions

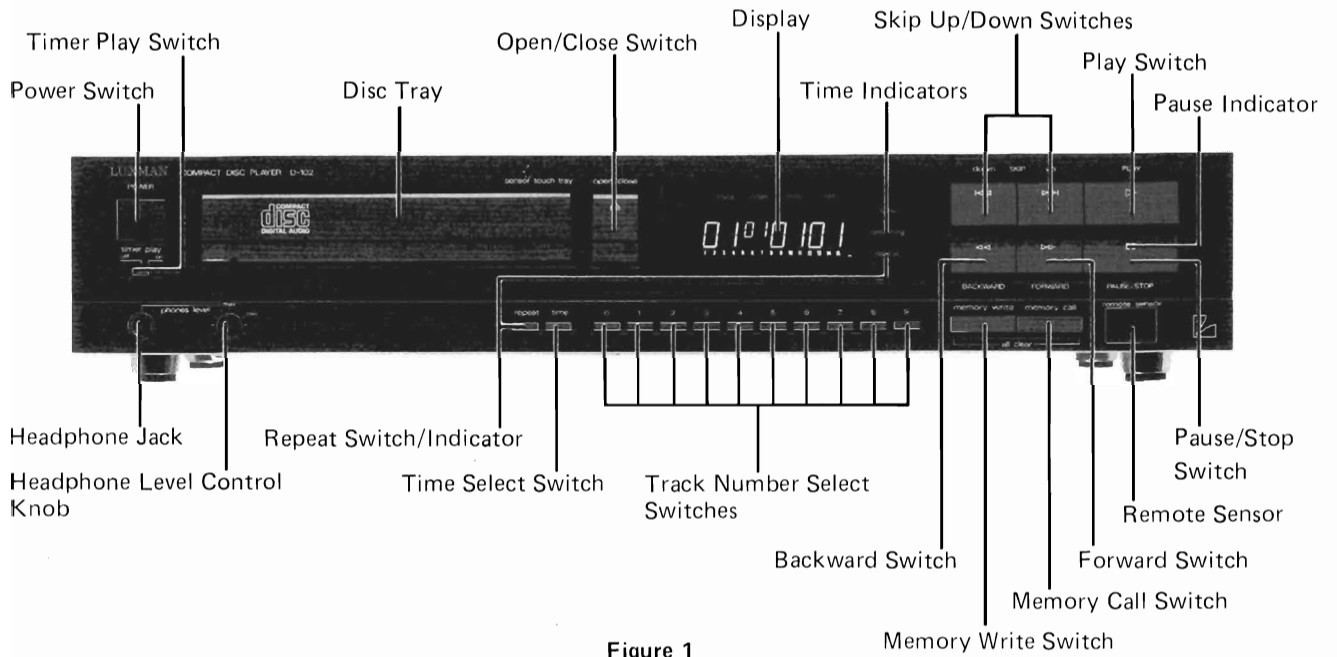

Figure 1

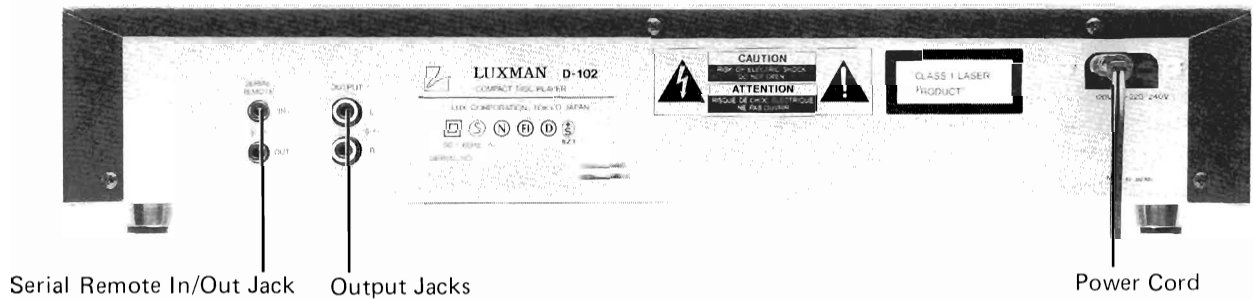

Figure 2

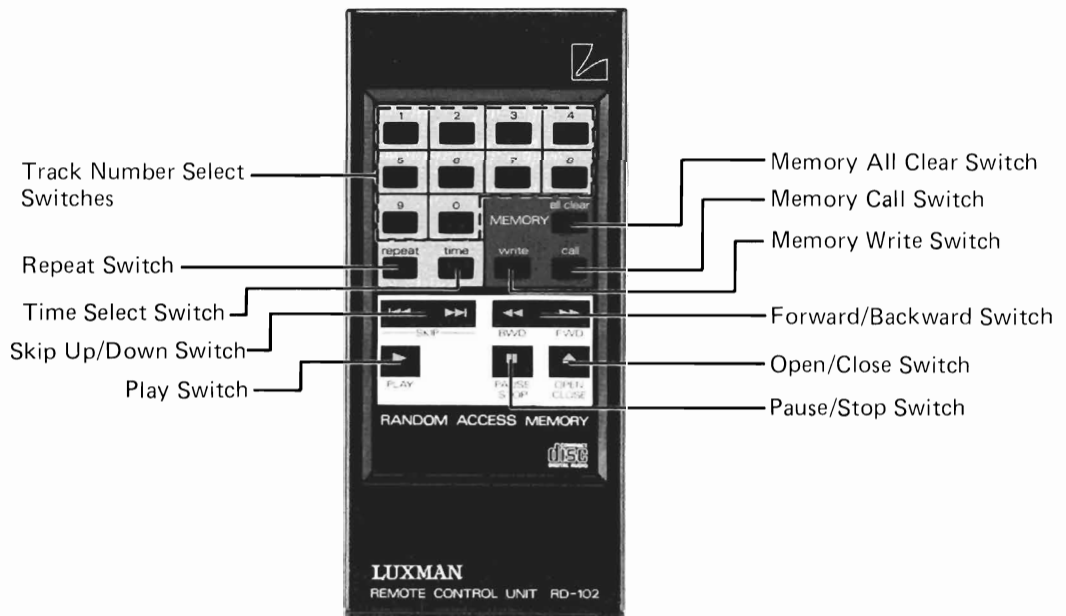

Figure 3

**1. Removal of Top Cover**

- (1) Remove eight screws marked "○" as shown in Figures 4 and 5-1.

**2. Removal of Tray Panel**

- (1) Open the disc tray.
- (2) Remove two hooks (a) as shown in Figure 6.

**3. Removal of Front Panel**

- (1) After removal of the tray panel, remove the level knob as shown in Figure 4.
- (2) Remove five screws marked "△" as shown in Figures 6 and 7.
- (3) Then remove display P.C. Board, timer play P.C. Board and phone level P.C. Board with the front panel.
- (4) Disconnect all wires from these P.C. Boards.

**4. Removal of Display P.C. Board**

- (1) After removal of the front panel, remove seven screws marked "□" as shown in Figure 8.
- (2) Remove hooks (b) as shown in Figure 8.

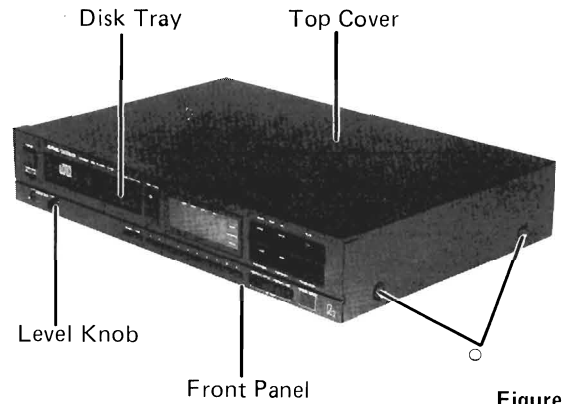

Figure 4

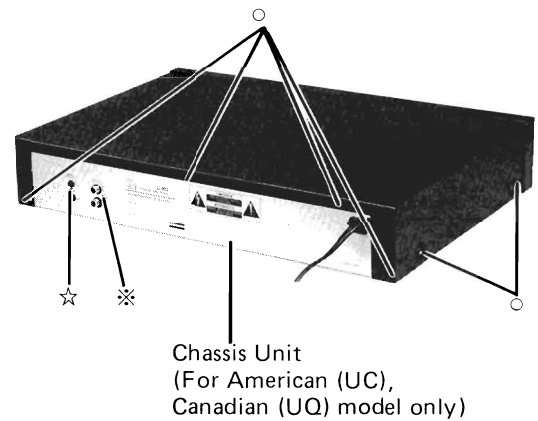

Figure 5-1

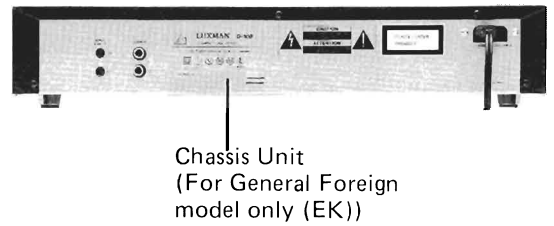

Figure 5-2

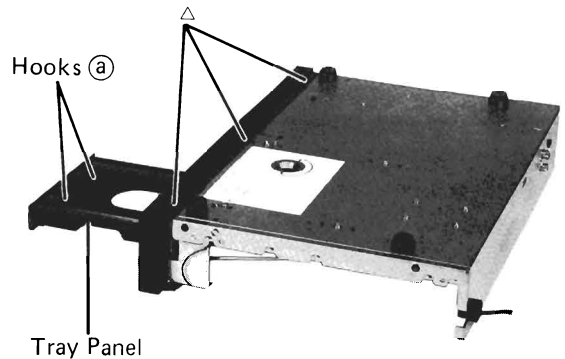

Figure 6

**5. Removal of Phone Level P.C. Board and Timer Play P.C. Board**

- (1) After removal of the front panel, remove one screw marked "●" as shown in Figure 8.
- (2) Remove two nuts as shown in Figure 9.
- (3) Thereby remove the Phone Level P.C. Board.
- (4) Remove two screws marked "▲" as shown in Figure 9.
- (5) Thereby remove the Timer Play P.C. Board.

**6. Removal of Mechanism Assembly**

- (1) After removal of the front panel, remove five screws marked "■" as shown in Figure 7.

**7. Removal of Main P.C. Board**

- (1) After removal of the mechanism assembly, remove three screws marked "※" as shown in Figures 5-1 and 7.
- (2) Disconnect all wires from the P.C. Board

**8. Removal of Serial Remote P.C. Board**

- (1) Remove one screw marked "☆" as shown in Figure 5-1.
- (2) Disconnect all wires from the P.C. Board.

**9. Removal of Terminal Power P.C. Board**

- (1) After removal of mechanism assembly, remove three rivets marked "★" as shown in Figure 7.
- (2) Remove five screws marked "☆" as shown in Figure 10.
- (3) Disconnect all wires from the P.C. Board.

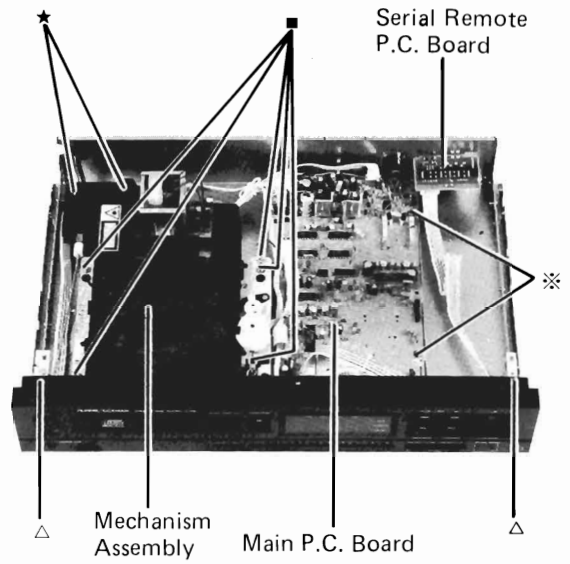

Figure 7

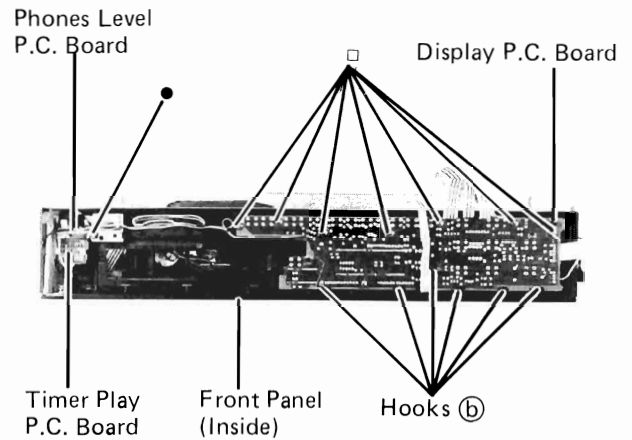

Figure 8

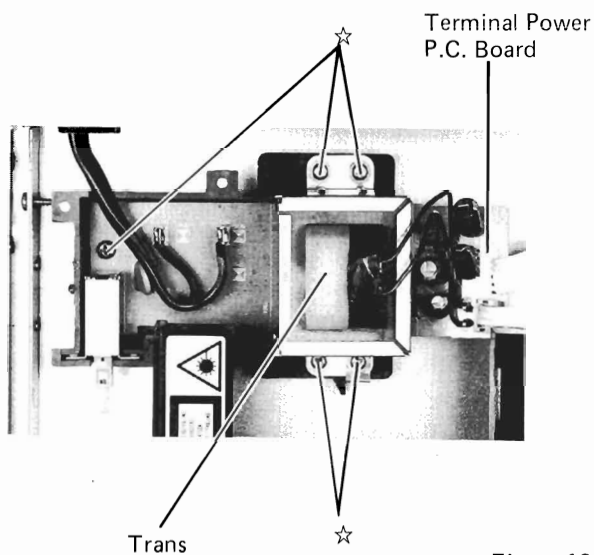

Figure 10

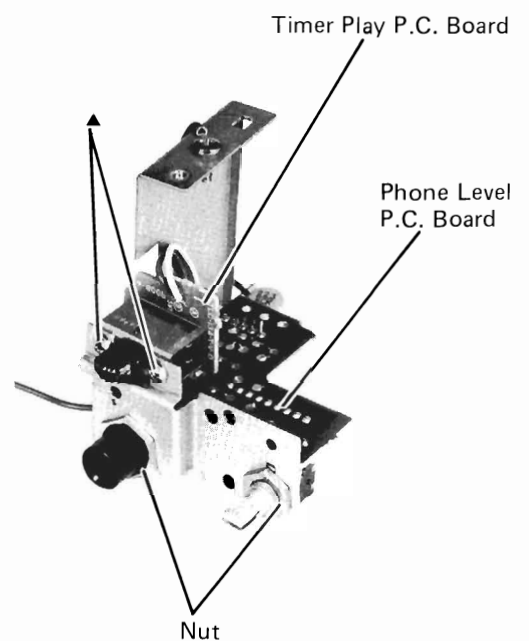
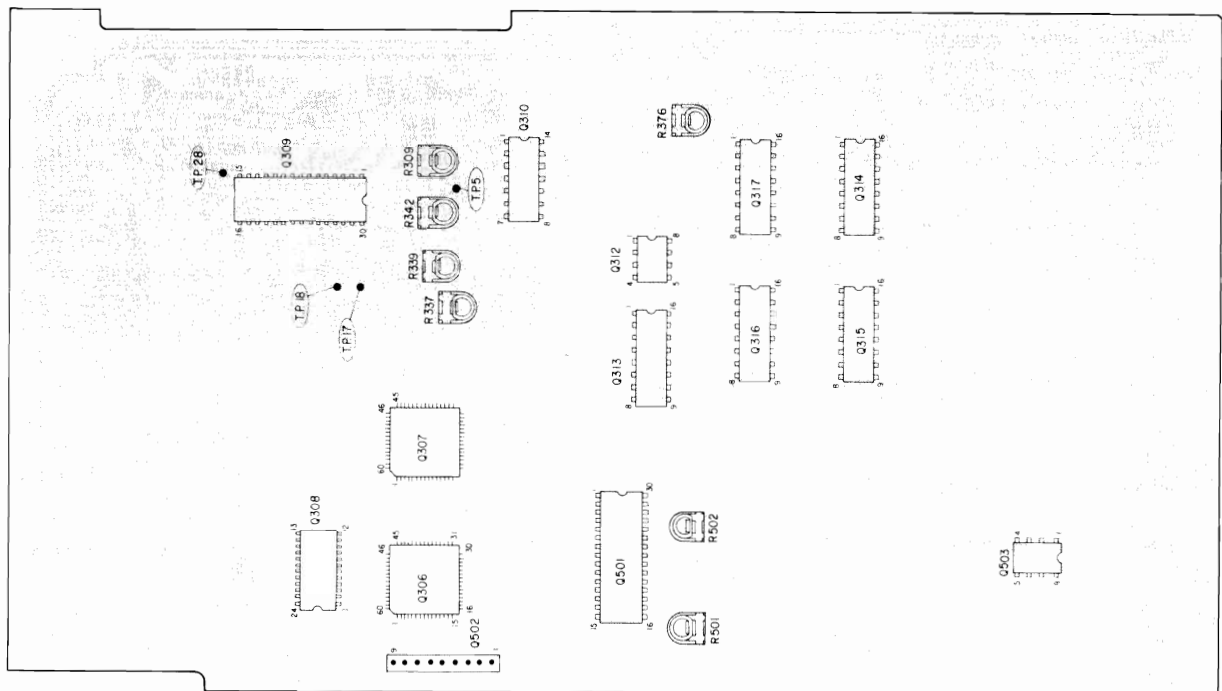

Figure 9

## Adjustment Locations



Main PC Board

Figure 11

## Adjustment Procedures

### Adjustment Procedures After Laser Pickup Replacement

1. Remove the tray and clamper.
2. Focus Balance and Offset Adjustments
  - (1) Set the unit to stop mode and connect the oscilloscope between T.P. 17 (FE) and T.P. 5 (VREF). (Focus error signal) (DC range: 5mV/DIV.)
  - (2) Adjust semi-fixed resistor R339 (100K ohm) so that DC offset obtains  $0V \pm 10mV$ .
  - (3) Play back YEDS-7 DISC. (Any Track number is available.)
  - (4) Connect the oscilloscope between T.P. 5 (VREF) and T.P. 28 (RF). (AC range: 0.2V/DIV., 0.5 $\mu$ sec./DIV.)
  - (5) Adjust semi-fixed resistor R342 (20K ohm) so that 3T component of RF signal obtains max.

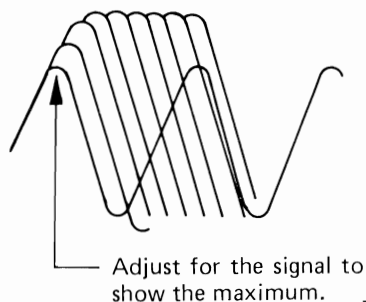

Figure 12

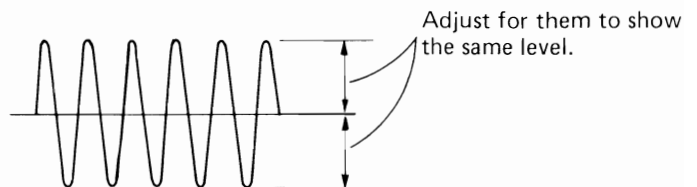

Figure 13

### 3. Tracking Error Balance and Offset Adjustments

- (1) Set the unit to stop mode and connect oscilloscope between T.P. 18 (TE signal) and T.P. 5 (VREF). (DC range: 5mV/DIV.)
- (2) Adjust semi-fixed resistor R337 (100K ohm) so that DC offset obtains  $0V \pm 10mV$ .
- (3) Play back YEDS-7 DISC and shift oscilloscope range to DC 0.5V/DIV, 5msec./DIV.
- (4) Set the unit to search mode by UP/DOWN key.
- (5) Adjust semi-fixed resistor R309 (100K ohm) so that DC offset of tracking error signal obtains  $0V$  during searching.

**4. Ansglog Output Offset Adjustment**

This adjustment is not needed when pickup is replaced.

- (1) Turn the power of the unit on.
- (2) Connect DC voltmeter or oscilloscope to Q503 pin 1 (L ch) and pin 7 (R ch) on Main P.C. Board.  
Adjust semi-fixed resistor R502 (50K ohm) (L ch) and R501 (50K ohm) (R ch) so that offset (DC range) obtains  $0 \pm 10\text{mV}$ .

**5. Disc Motor Brake Adjustment**

- (1) Short-circuit pins 3 and 4 of Q313 (TC40538P) and connect pin 14 (T.P. 26) to VREF (T.P. 5).
- (2) Turn power on and connect oscilloscope probes to pin 7 of Q313 and VREF (T.P. 5). (5mV range)
- (3) Adjust semi-fixed VR R376 (50K ohm) by turning it so that voltage output obtains within  $\pm 5\text{mV}$ .

**6. Cautions on Laser Pickup Removal**

- (1) When removing laser pickup, solder and short-circuit patterns or leads to protect laser pickup from damage which may be caused during the removal. (Refer to Figures 4 and 6.)
- (2) Disconnect leads from connector after soldering is completed. Do not touch the pickup terminals with your hand.
- (3) When mounting laser pickup, connect the leads to connector before unsoldering the solder used to short-circuit.

**7. Cautions on Laser Pickup Replacement**

- (1) When mounting a new laser pickup, first connect the leads to connectors and then unsolder the solder used to protect laser diode on P.C. Board. (Refer to Figures 15 and 17.)
- \* Use a soldering iron grounded (or leakageless iron).
- \* Cover working bench with conductive mat grounded.
- \* Before proceeding job, always touch the conductive mat or ground lead with your both hands to discharge electric charges developed on your body.

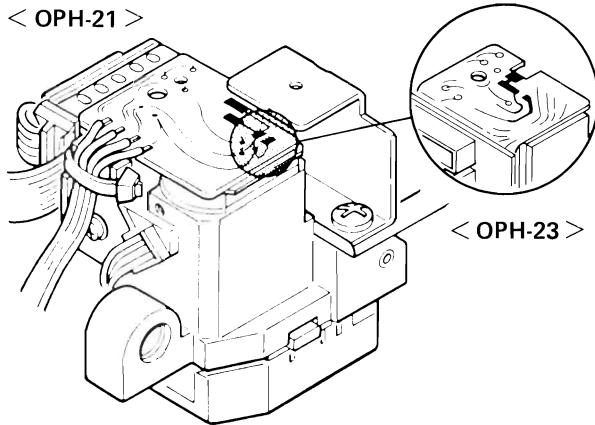

Figure 14

- Solder the patterns as shown in the illustration before disconnecting connector and leads.

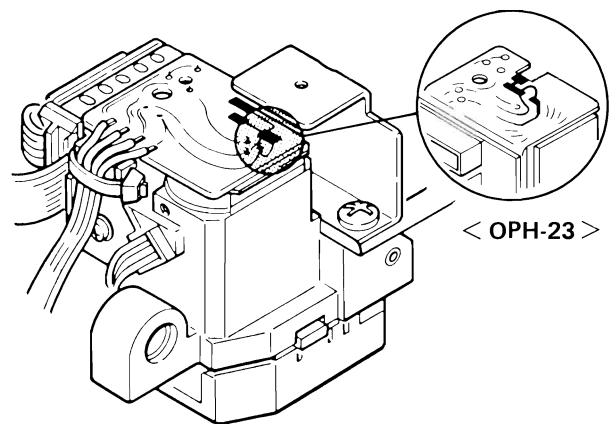

Figure 15

- Soldered condition.

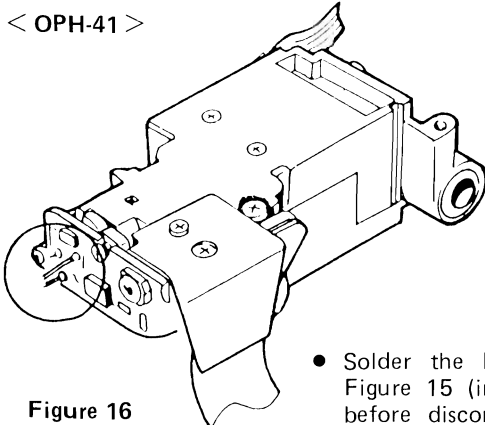

Figure 16

- Solder the leads as shown in Figure 15 (indicated by circle) before disconnecting lead connectors.

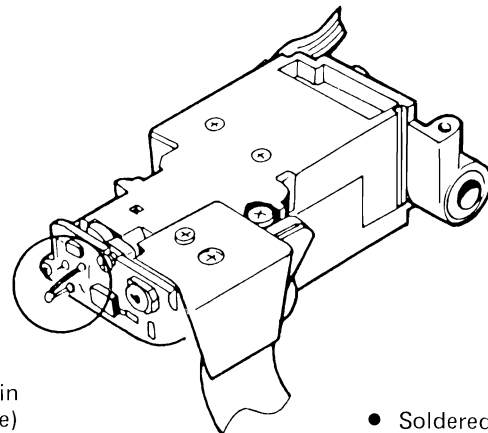

Figure 17

- Soldered condition.

**CAUTION:** The necessary distance between laser pickup and the viewers eye is only 2mm.

OPH-21	Patterns Figure 14.
OPH-23	
OPH-41	Leads Figure 16.

# Block Diagram

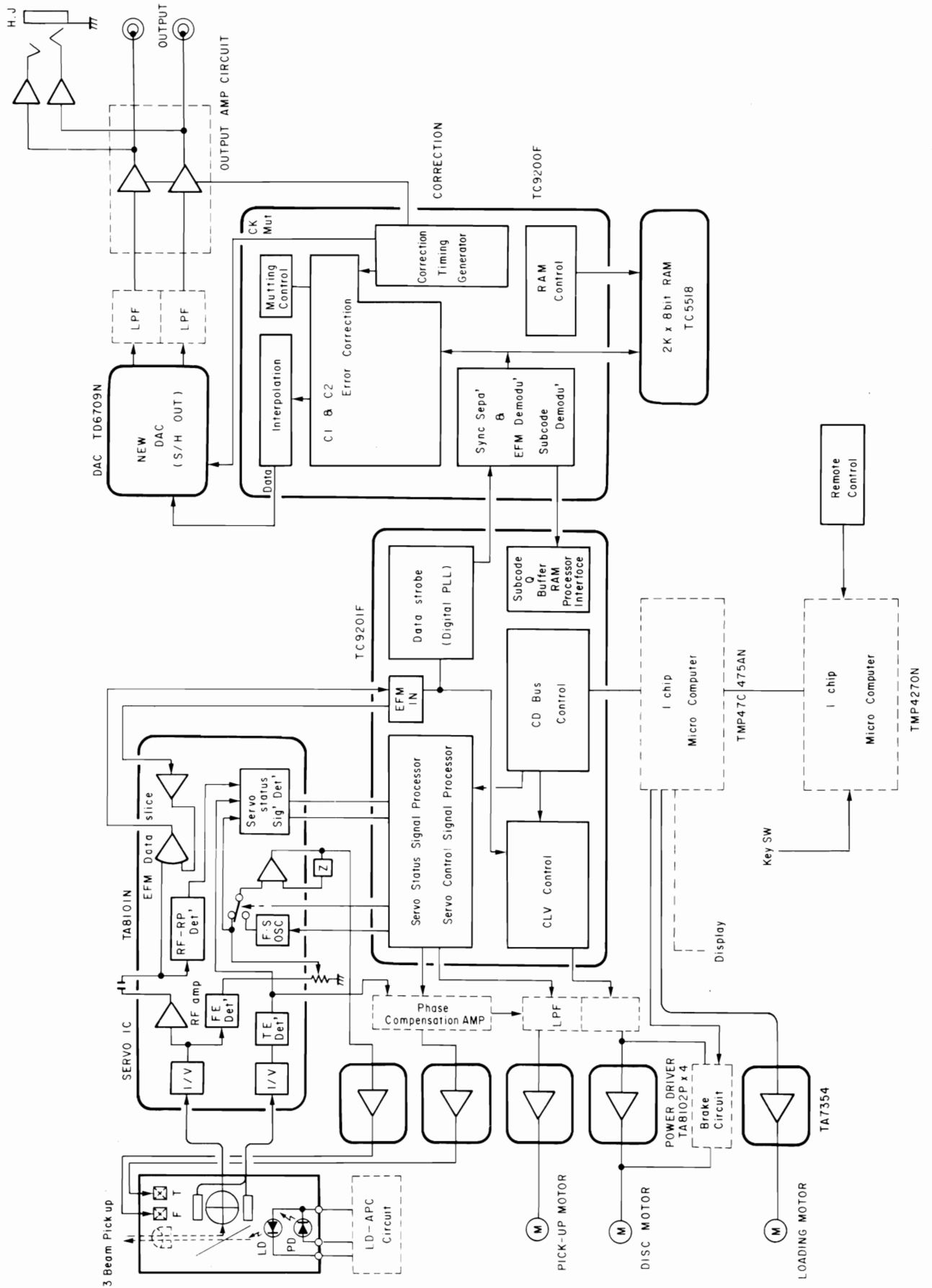



# Schematic Diagram

IC	1: Q102	2: Q312	3: Q310	Q307
	Q202	Q301 Q303	Q314 ~ Q317	Q201
Transistor(Q)	Q203	Q101	Q302	Q601 Q602 Q603 Q604
	Q204		Q311 Q318	Q903 ~ Q911
Diode (D)	D101	D102	D304 D305	D302 D303
	D205		D213	D214
			D203 D206 ~ D212	D204 D201 D202
				D301
				D904 ~ D907
				D914 D908 D909 ~

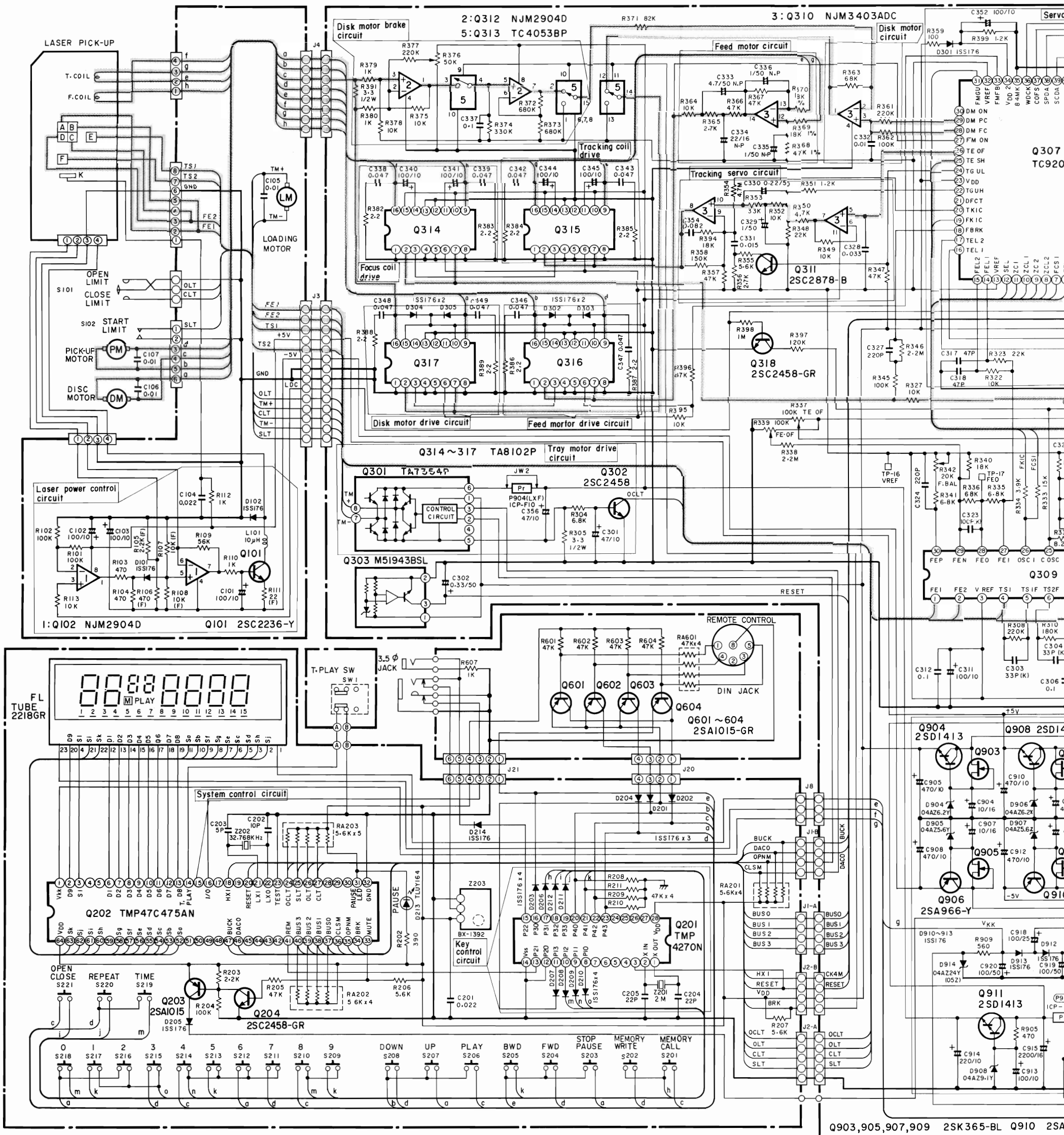

Q307	Q309	Q306	Q502	Q308	Q551	Q1		
			4: Q503	Q501	Q552			
				1: Q701				
Q903 ~ Q911	Q902	Q901	Q506	Q504	Q505	Q507	Q508	Q1
D301	D306	D902	D903	D901	D915	D1 ~ D4	D1	
D904 ~ D907	D914	D908	D909 ~ D913					

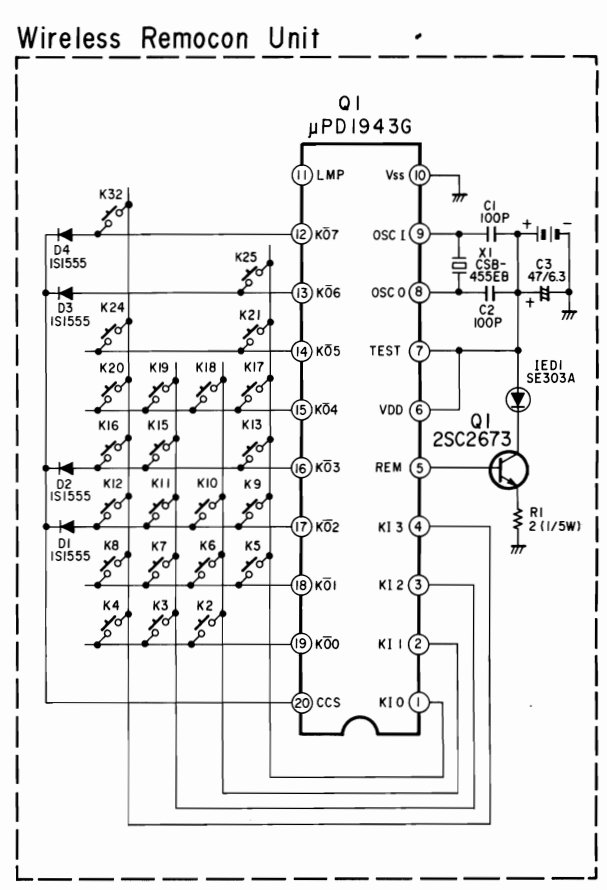
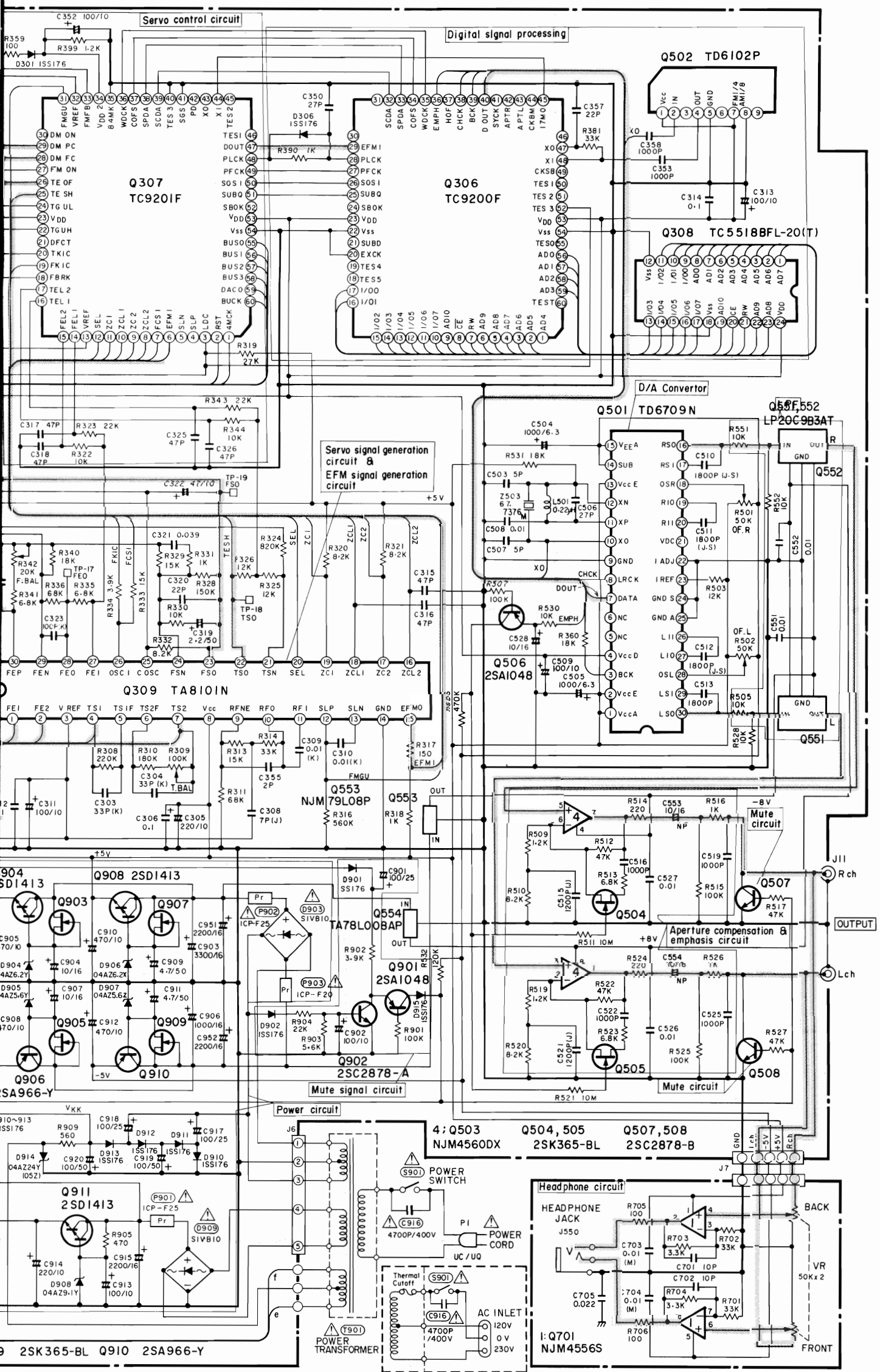

NOTES:  
 1. All resistance values are in ohms, K = 1,000  
 2. All capacitance values are in microfarads, P =  $\frac{1}{1,000,000}$

# Parts Layout on P.C. Boards and Wiring Diagram

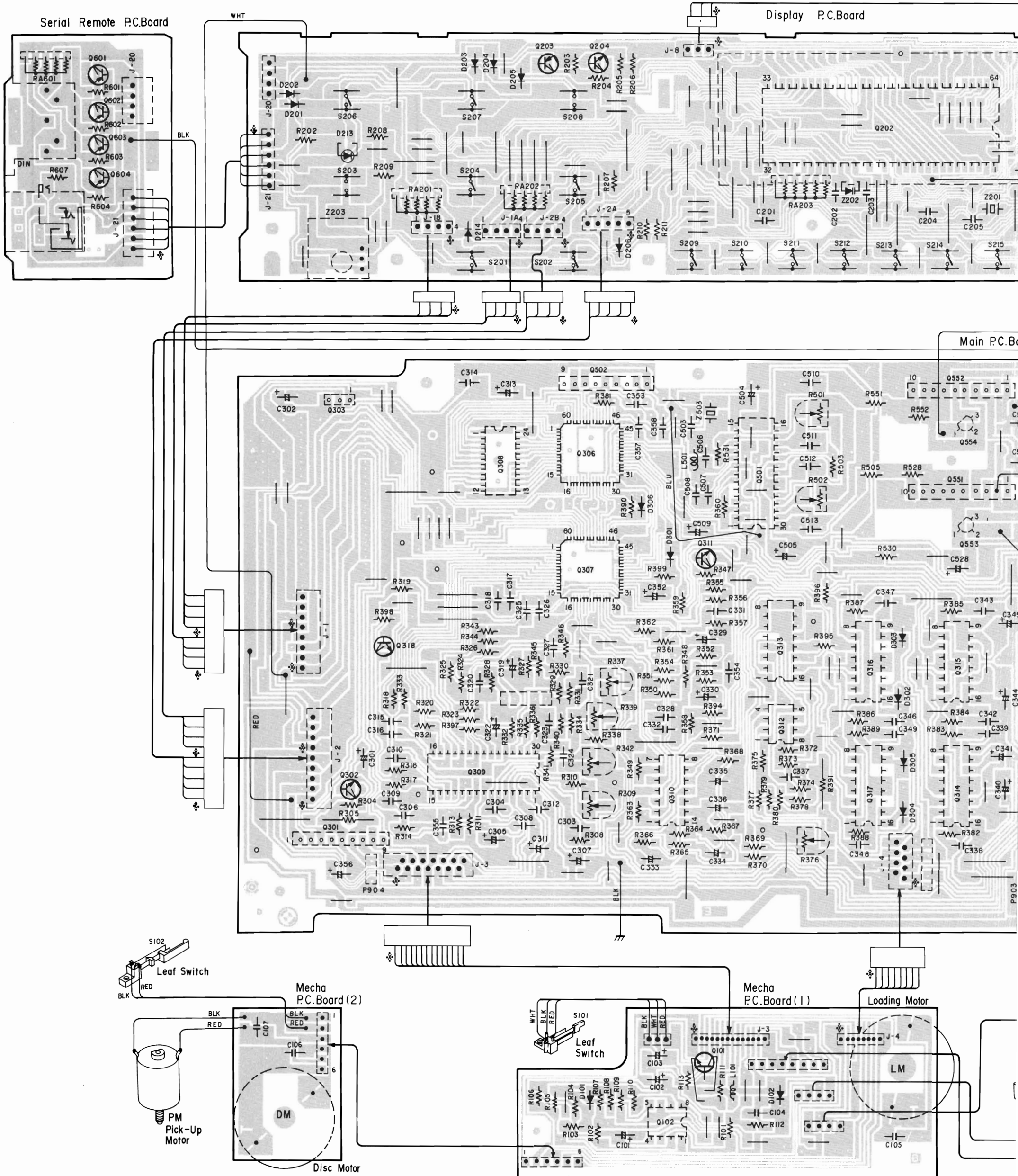





# Electrical Parts List

Resistors: Carbon resistors under ¼ watts are not mentioned in the parts list, please confirm them by schematic diagram.  
 uF = microfarads, pF = picofarads

Symbol No.	Part No.	Description
<b>IC's/Transistors</b>		
Q101	36325540	Transistor, 2SC2236
Q102	22117698	IC, NJM2904D
Q201	40517667	IC, TMP47C475AN9671
Q202	40402258	IC, TMP4270N-9401
Q203	36534069	Transistor, 2SA1015
Q204	36332440	Transistor, 2SC2458
Q301	40325461	IC, TA7354P
Q302	36332460	Transistor, 2SC2458
Q303	22117892	IC, M51943BSL
Q306	40412002	IC, TC9200F
Q307	40412016	IC, TC9201AF
Q309	40377580	IC, TA8101N
Q310	22117709	IC, NJM3403AD
Q311	36342214	Transistor, 2SC2878
Q312	22117698	IC, NJM2904D
Q313	40470532	IC, TC4053BP
Q314	40377590	IC, TA8102P
Q315	40377590	IC, TA8102P
Q316	40377590	IC, TA8102P
Q317	40377590	IC, TA8102P
Q318	36332460	Transistor, 2SC2458
Q501	40272760	IC, TD6709N
Q502	40271774	IC, TD6102P
Q503	22114866	IC, NJM4560DX
Q504	36058731	FET, 2SK365
Q505	36058731	FET, 2SK365
Q506	36534448	Transistor, 2SA1048
Q507	36342214	Transistor, 2SC2878
Q508	36342214	Transistor, 2SC2878
Q551	22117885	IC, LP20C9B3AT
Q552	22117885	IC, LP20C9B3AT
Q553	22117915	IC, NJM79L08A
Q554	40372860	Transistor, TA78L008AP
Q601	36534069	Transistor, 2SA1015
Q602	36534069	Transistor, 2SA1015
Q603	36534069	Transistor, 2SA1015
Q604	36534069	Transistor, 2SA1015
Q701	22117838	IC, NJM4556S
Q901	36534448	Transistor, 2SA1048
Q902	36342204	Transistor, 2SC2878

Symbol No.	Part No.	Description
Q903	36058731	FET, 2SK365
Q904	36868350	Transistor, 2SD1413
Q905	36058731	FET, 2SK365
Q906	36533244	Transistor, 2SA966
Q907	36058731	FET, 2SK365
Q908	36868350	Transistor, 2SD1413
Q909	36058731	FET, 2SK365
Q910	36533244	Transistor, 2SA966
Q911	36868350	Transistor, 2SD1413
<b>Diodes/LED's</b>		
D201	37160571	1SS176
D202	37160571	1SS176
D203	37160571	1SS176
D204	37160571	1SS176
D205	37160571	1SS176
D206	37160571	1SS176
D207	37160571	1SS176
D208	37160571	1SS176
D209	37160571	1SS176
D210	37160571	1SS176
D211	37160571	1SS176
D212	37160571	1SS176
D213	38690750	LED, TLUY164
D214	37160570	1SS176
D301	37160571	1SS176
D302	37160571	1SS176
D303	37160571	1SS176
D303	37160571	1SS176
D304	37160571	1SS176
D305	37160571	1SS176
D306	37160571	1SS176
D901	37160571	1SS176
D902	37160571	1SS176
D903	22119188	Bridge, SIVB10
D904	37116526	Zener, 04AZ6.2Z
D905	37116416	Zener, 04AZ5.6Y
D906	37116507	Zener, 04AZ6.2X
D907	37116416	Zener, 04AZ5.6Y
D908	37116917	Zener, 04AZ9.1Y
D909	22119188	Bridge, SIVB10

Symbol No.	Part No.	Description	Symbol No.	Part No.	Description
D910	37160571	1SS176	C321	22371393	MY 0.039 uF/50V, J
D911	37160571	1SS176	C322	22483470	EL 47 uF/10V
D912	37160571	1SS176	C323	22349101	CD 100 pF/50V, K
D913	37160571	1SS176	C324	22349221	CD 220 pF/50V, K
D914	37110664	Zener, 05Z24-Y	C325	22361470	CD 47 pF/50V, J
D915	37160571	1SS176	C326	22361470	CD 47 pF/50V, J
<b>Capacitors</b>			C327	22349221	CD 220 pF/50V, K
uF = microfarads, pF = picofarads			C328	22371333	MY 0.033 uF/50V, J
D = $\pm 0.5$ pF, J = $\pm 5\%$ , K = $\pm 10\%$ , M = $\pm 20\%$ ,			C329	22488109	EL 1 uF/50V
Z = -20+80%, P = 0+100%			C330	22488228	EL 0.22 uF/50V
ABBREVIATIONS: BL = Barrier Layer,			C331	22371153	MY 0.015 uF/50V, J
CD = Ceramic Disk,			C332	22360544	BL 0.01 uF/25V, K
EL = Electrolytic, MY = Mylar,			C333	22476479	EL 4.7 uF/25V
PP = Polypropylene			C334	22473220	EL 22 uF/10V
C201	22342223	BL 0.022 uF/50V, Z	C335	22478109	EL 1 uF/50V
C202	22361100	CD 10 pF/50V	C336	22478109	EL 1 uF/50V
C203	22361509	CD 5 pF/50V	C337	22371104	MY 0.1 uF/50V, J
C204	22361220	CD 22 pF/50V, J	C338	22360881	BL 0.047 uF/16V, Z
C205	22361220	CD 22 pF/50V, J	C339	22360881	BL 0.047 uF/16V, Z
C301	22483470	EL 47 uF/10V	C340	22483101	EL 100 uF/10V
C302	22488338	EL 0.33 uF/50V	C341	22483101	EL 100 uF/10V
C303	22361330	CD 33 pF/50V, J	C342	22360881	BL 0.047 uF/16V, Z
C304	22361330	CD 33 pF/50V, J	C343	22360881	BL 0.047 uF/16V, Z
C305	22483221	EL 220 uF/10V	C344	22483101	EL 100 uF/10V
C306	22360880	BL 0.1 uF/16V, Z	C345	22483101	EL 100 uF/10V
C307	22485220	EL 22 uF/16V	C346	22360881	BL 0.047 uF/16V, Z
C308	22361709	CD 7 pF/50V, D	C347	22360881	BL 0.047 uF/16V, Z
C309	22360544	BL 0.01 uF/25V, K	C348	22360881	BL 0.047 uF/16V, Z
C310	22360544	BL 0.01 uF/25V, K	C349	22360881	BL 0.047 uF/16V, Z
C311	22483101	EL 100 uF/10V	C352	22483101	EL 100 uF/10V
C312	22360880	BL 0.1 uF/16V, Z	C353	22349102	CD 1000 pF/50V, K
C313	22483101	EL 100 uF/10V	C354	22371823	MY 0.082 uF/50V, J
C314	22360880	BL 0.1 uF/16V, Z	C355	22361209	CD 2 pF/50V, J, CH
C315	22361470	CD 47 pF/50V, J	C356	22483470	EL 47 uF/10V
C316	22361470	CD 47 pF/50V, J	C357	22361220	CD 22 pF/50V, J
C317	22361470	CD 47 pF/50V, J	C358	22349102	CD 1000 pF/50V, K
C318	22361470	CD 47 pF/50V, J	C503	22361509	CD 5 pF/50V, D
C319	22488229	EL 2.2 uF/50V	C504	22482102	EL 1000 uF/6.3V
C320	22361220	CD 22 pF/50V, J	C505	22482102	EL 1000 uF/6.3V
			C506	22361270	CD 27 pF/50V, J
			C507	22361509	CD 5 pF/50V, D
			C508	22342103	CD 0.01 uF/50V, Z
			C509	22482331	EL 330 uF/6.3V
			C510	22321060	PP 1800 pF/50V, J
			C511	22321060	PP 1800 pF/50V, J

Symbol No.	Part No.	Description	
C512	22321060	PP	1800 pF/50V, J
C513	22321060	PP	1800 pF/50V, J
C515	22321058	PP	1200 pF/50V, J
C516	22371102	MY	1000 pF/50V, J
C519	22371102	MY	1000 pF/50V, J
C521	22321058	PP	1200 pF/50V, J
C522	22371102	MY	1000 pF/50V, J
C525	22371102	MY	1000 pF/50V, J
C526	22371103	MY	0.01 uF/50V, J
C527	22371103	MY	0.01 uF/50V, J
C528	22485100	EL	10 uF/16V
C551	22371473	EL	0.047 uF/50V, J
C552	22371473	EL	0.047 uF/50V, J
C553	20450003	EL	10 uF/16V
C554	20450003	EL	10 uF/16V
C701	22361100	CD	10 uF/50V
C702	22361100	CD	10 uF/50V
C703	22371103	MY	0.01 uF/50V, J
C704	22371103	MY	0.01 uF/50V, J
C705	22342223	BL	0.022 uF/50V, Z
C901	22486101	EL	100 uF/250V
C902	22483101	EL	100 uF/250V
C903	22460035	EL	3300 uF/16V
C904	22485100	EL	10 uF/16V
C905	22483471	EL	470 uF/10V
C906	22485102	EL	1000 uF/16V
C907	22485100	EL	10 uF/16V
C908	22483471	EL	47 uF/10V
C909	22488479	EL	4.7 uF/50V
C910	22483471	EL	47 uF/10V
C911	22488479	EL	4.7 uF/50V
C912	22483471	EL	470 uF/10V
C913	22483101	EL	100 uF/10V
C914	22483221	EL	220 uF/10V
C915	22485222	EL	2200 uF/16V
C916	22340232	CD	0.047 uF
C917	22486101	EL	100 uF/25V
C918	22486101	EL	100 uF/25V
C919	22488101	EL	100 uF/50V
C920	22488101	EL	100 uF/50V
C951	22440604	EL	2200 uF/16V
C952	22440604	EL	2200 uF/16V

Symbol No.	Part No.	Description	
<b>Resistors</b>			
All resistors are carbon film 1/6W, $\pm 5\%$ unless otherwise noted. K = 1000, M = 1000000			
R202	22584391		390 ohm
R203	22584222		2.2K ohm
R204	22584104		100K ohm
R205	22584473		47K ohm
R206	22584562		5.6K ohm
R207	22584562		5.6K ohm
R208	22584473		47K ohm
R209	22584473		47K ohm
R210	22584473		47K ohm
R211	22584473		47K ohm
R304	22584682		6.8K ohm
R305	22547339		3.3 ohm x 1/2W
R308	22584224		220K ohm
R309	22658884	Variable	100K ohm
R310	22584184		180K ohm
R311	22584683		68K ohm
R813	22584153		15K ohm
R314	22584333		33K ohm
R316	22584564		560K ohm
R317	22584151		150 ohm
R318	22584102		1K ohm
R319	22584273		27K ohm
R320	22584822		8.2K ohm
R321	22584822		8.2K ohm
R322	22584103		10K ohm
R323	22584223		22K ohm
R324	22584824		820K ohm
R325	22584123		12K ohm
R326	22584123		12K ohm
R327	22584103		10K ohm
R328	22584154		150K ohm
R329	22584153		15K ohm
R330	22584103		10K ohm
R331	22584102		1K ohm
R332	22584222		8.2K ohm
R333	22584153		15K ohm
R334	22584392		3.9K ohm
R335	22584682		6.8K ohm
R336	22584683		68K ohm
R337	22658884	Variable	100K ohm

Symbol No.	Part No.	Description	Symbol No.	Part No.	Description
R338	22584225	2.2M ohm	R383	22584229	2.2 ohm
R339	22658884	Variable 100K ohm	R384	22584229	2.2 ohm
R340	22584183	18K ohm	R385	22584229	2.2 ohm
R341	22584682	6.8K ohm	R386	22584229	2.2 ohm
R342	22658901	Variable 20K ohm	R387	22584229	2.2 ohm
R343	22584223	22K ohm	R388	22584229	2.2 ohm
R344	22584103	10K ohm	R389	22584229	2.2 ohm
R345	22584104	100K ohm	R390	22584102	1K ohm
R346	22584225	2.2M ohm	R391	22547339	3.3 ohm, 1/2W
R347	22584374	47K ohm	R394	22584183	18K ohm
R348	22584223	22K ohm	R395	22584103	10K ohm
R349	22584103	10K ohm	R396	22584473	47K ohm
R350	22584472	4.7K ohm	R397	22584124	120K ohm
R351	22584122	1.2K ohm	R398	22584105	1M ohm
R352	22584103	10K ohm	R399	22584122	1.2K ohm
R353	22584333	33K ohm	R501	22658828	Variable 50K ohm
R354	22555475	4.7M ohm	R502	22658828	Variable 50K ohm
R355	22584562	5.6K ohm	R503	22584123	12K ohm
R356	22584272	2.7K ohm	R505	22584103	10K ohm
R357	22584473	47K ohm	R506	22584474	470K ohm
R358	22584154	150K ohm	R507	22584104	100K ohm
R359	22584101	100 ohm	R509	22584122	1.2K ohm
R360	22584183	18K ohm	R510	22584822	8.2K ohm
R361	22584224	220K ohm	R511	22555106	10M ohm, 1/4W
R362	22584104	100K ohm	R512	22584473	47K ohm
R363	22584683	68K ohm	R513	22584682	6.8K ohm
R364	22584103	10K ohm	R514	22555221	220 ohm
R365	22584272	2.7K ohm	R515	22584104	100K ohm
R366	22584473	47K ohm	R516	22555102	1K ohm
R367	22570743	Metal Film 47K ohm	R517	22584473	47K ohm
R368	22570743	Metal Film 47K ohm	R519	22584122	1.2K ohm
R369	22570738	Metal Film 18K ohm, 1/2W	R520	22584822	8.2K ohm
R370	22570738	Metal Film 18K ohm, 1/2W	R521	22555106	10M ohm, 1/4W
R371	22584823	82K ohm	R522	22584473	47K ohm
R372	22584684	680K ohm	R523	22584682	6.8K ohm
R373	22584684	680K ohm	R524	22555221	220 ohm
R374	22584334	330K ohm	R525	22584104	100K ohm
R375	22584103	10K ohm	R526	22555102	1K ohm
R376	22658828	Variable 50K ohm	R527	22584473	47K ohm
R377	22584224	220K ohm	R528	22584103	10K ohm
R378	22584103	10K ohm	R530	22584103	10K ohm
R379	22584102	1K ohm	R531	22584183	18K ohm
R380	22584102	1K ohm	R532	22584124	120K ohm
R381	22584333	33K ohm	R551	22584103	10K ohm
R382	22584229	2.2 ohm	R552	22584103	10K ohm



Symbol No.	Part No.	Description	Symbol No.	Part No.	Description
R601	22584562	5.6K ohm	RJ	22120116	Jack, Remote Control
R602	22584562	5.6K ohm	RJ	22120116	Jack, Remote Control
R603	22584562	5.6K ohm	S101	22196719	Switch, Leaf-1C1P
R604	22584562	5.6K ohm	S102	22196598	Switch, Leaf-1C2P
R607	22584102	1K ohm	S201	22196796	Key Switch
R701	22584333	33K ohm	S202	22196796	Key Switch
R702	22584333	33K ohm	S203	22196796	Key Switch
R703	22584332	3.3K ohm	S204	22196796	Key Switch
R704	22584332	3.3K ohm	S205	22196796	Key Switch
R705	22584101	100 ohm	S206	22196796	Key Switch
R706	22584101	100 ohm	S207	22196796	Key Switch
R901	22584104	100K ohm	S208	22196796	Key Switch
R902	22584392	3.9K ohm	S209	22196858	Key Switch
R903	22584562	5.6K ohm	S210	22196858	Key Switch
R904	22584223	22K ohm	S211	22196858	Key Switch
R905	22584471	470 ohm	S212	22196858	Key Switch
R909	22584561	560 ohm	S213	22196858	Key Switch
RA201	22540655	5.6K ohm x 4	S214	22196858	Key Switch
RA202	22540655	5.6K ohm x 4	S215	22196858	Key Switch
RA203	22540649	5.6K ohm x 5	S216	22196858	Key Switch
RA601	22540264	47K ohm x 4	S217	22196858	Key Switch
<b>Miscellaneous</b>			S218	22196858	Key Switch
DM	25792092	Disc Motor	S219	22196858	Key Switch
HJ	22198062	Jack, 6D-HP	S220	22196858	Key Switch
J11	22198227	Jack, US, 2P-P	S221	22196796	Key Switch
L501	22291401	Choke Coil, 0.22 $\mu$ H	S901	22196362	Switch, Power
LM	25792093	Loading Motor	S1	22196775	Switch, Slide-6C2P
● P1	22176574	Power Cord	● T901	22224871	Power Transformer
▲ P1	22176574	Power Cord	▲ T901	22224871	Power Transformer
■ P1	22169173	Socket, AC-39	■ T901	22224872	Power Transformer
P901	22118223	ICP-F25-1.0A-S	VR	22611413	Variable Resistor 50K ohm, A
P902	22118223	ICP-F25-1.0A-S	Z201	22153383	Crystal, CSA2.00MK11
P903	22118229	ICP-F20-0.8A-S	Z202	22153273	X-RV-38-32K
P904	22118224	ICP-F10-0.4A-S	Z203	22117745	IC, BX-1392
PM	25792091	Pick Up Motor	Z501	22137780	Low-pass-filter
RJ	22120116	Jack, Remote Control	Z502	22137780	Low-pass-filter
RJ	22120116	Jack, Remote Control	Z503	22153390	Oscillator, 67 MHz

**Note:** ● : For North American model only (UC), ■ : For General Foreign model only (EK),  
▲ : For Canadian model only (UQ), Others: Common

## Cabinet Assembly Parts List

Symbol No.	Index	Part No.	Description	Symbol No.	Index	Part No.	Description
	1	2-B	20823133		47	1-C	20036111
●	2	1-F	22719456		50	2-G	22707910
▲	2	1-F	22719456		51	4-G	25872449
■	2	1-F	22179457		53	2-E	22707364
	4	6-G	20017354				
	5	6-H	20831935				
	6	6-G	20872220				
	7	6-H	20872272				
	8	5-F	20872225				
	9	6-G	20872226				
	10		22707185				
	11		22707911				
	12		22707842				
	13		22707844				
	14	2-C	22708022				
	15		22707798				
	19	1-C	22747145				
	20	4-C	22764372				
	21	4-C	22764307				
	22	4-E	25761545				
●	23	2-D	25844322				
▲	23	2-D	25844322				
	24	2-H	20024286				
	26	1-E	22708118				
	27	4-G	20872216				
	28	2-H	20872217				
	29	4-G	20872218				
	30		22707326				
	31	4-G	25872391				
	34	4-E	20844258				
	35	2-G	22874085				
	36	2-G	22708033				
	37		22708045				
	38		22708593				
	40		22705020				
	41	6-G	22705020				
	42	4-C	22702202				
	43	3-C	22707445				
	44	6-F	22708528				
	45	4-E	22764374				
	46	3-D	25779619				

Note: ● : For North American model only (UC), ■ : For General Foreign model only (EK),  
▲ : For Canadian model only (UQ), Others: Common

# Exploded View (Cabinet)

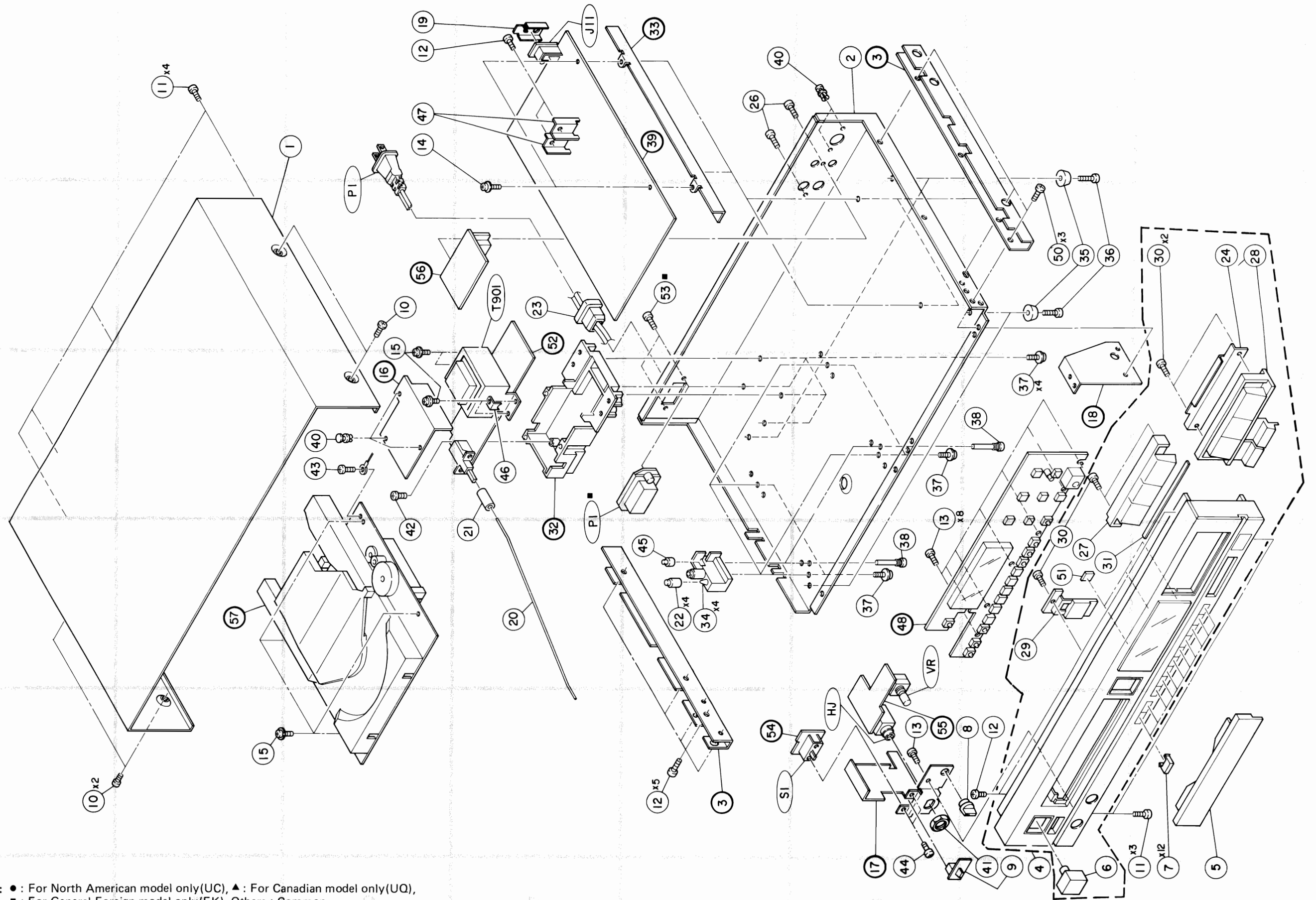

Note: ● : For North American model only(UC), ▲ : For Canadian model only(UQ),  
 ■ : For General Foreign model only(EK), Others : Common

### Exploded View (Mechanism)

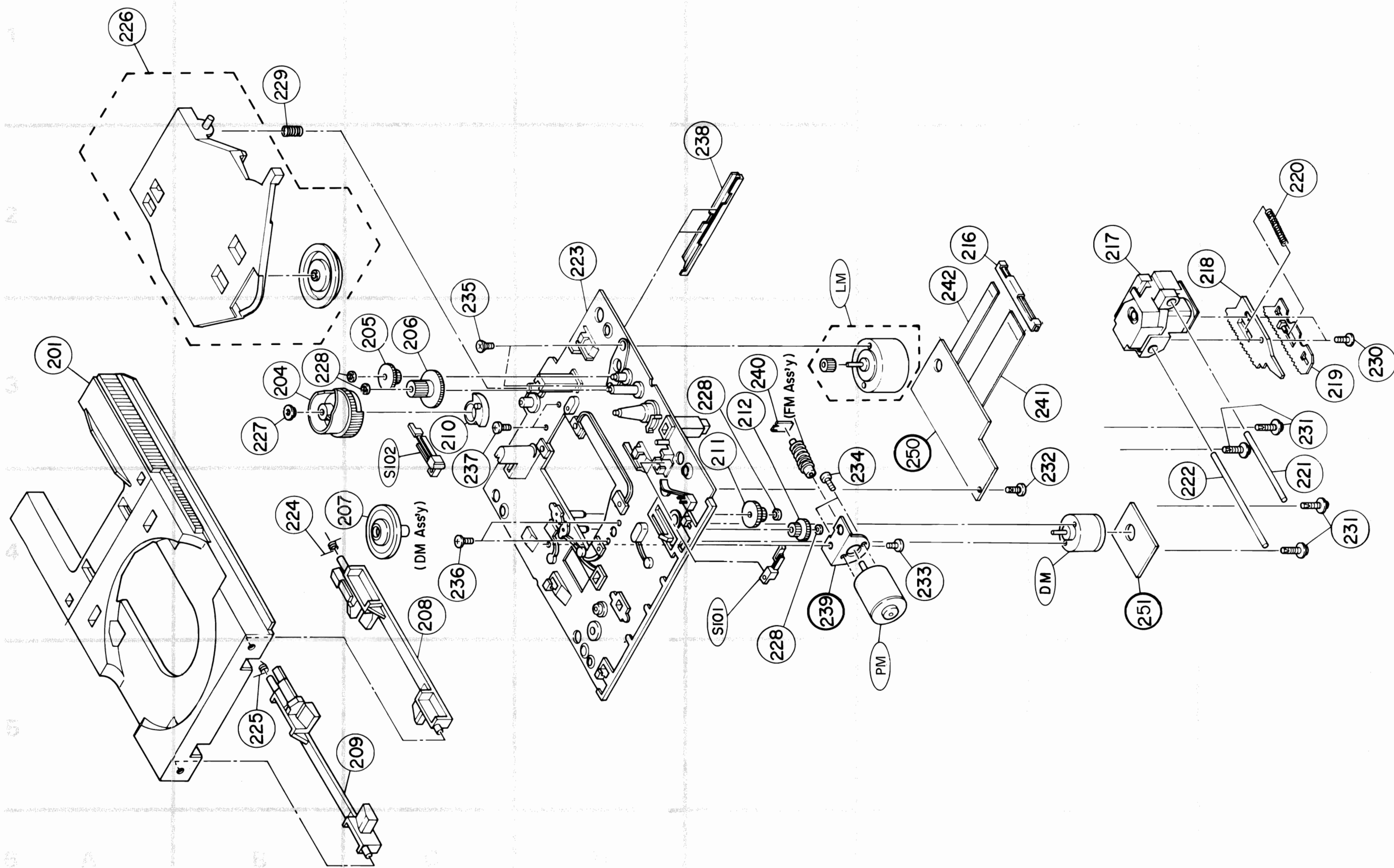

## Mechanism Assembly Parts List

Symbol No.	Index	Part No.	Description	Symbol No.	Part No.	Description
201	3-A	20778195	Disc, Tray			
204	3-B	20727166	Gear, Cam			
205	3-C	20727164	Gear, Drive-A			
206	3-C	20727165	Gear, Drive-B			
207	4-C	20723159	Disc, Table			
208	4-C	20754257	Disc, Lifter (R)			
209	5-C	20754256	Disc, Lifter (L)			
210	3-C	20754255	Cam, Switch			
211	3-E	20727161	Gear, Pulley Drive-A			
212	3-E	20727162	Gear, Pulley Drive-B			
216	2-F	25853064	Edging-PC			
217	2-G	22155214	Laser Pick-up OPH-23			
218	2-H	20727159	Gear, Rack (A)			
219	3-H	20727160	Gear, Rack (B)			
220	2-H	25777533	Spring, Rack			
221	4-H	20764280	Shaft Guide-A			
222	4-H	20764266	Shaft Guide-B			
223	2-D	20743180	Chassis, Main			
224	4-B	25778401	Spring, Lifter (L)			
225	5-B	25778400	Spring, Lifter (R)			
226	1-A	25792076	Assembly, Clamper lever			
227	3-B	25783444	Bushing			
228		25783443	Bushing			
229	1-B	25777531	Spring, Clamper Lever			
230	3-I	22708531	Screw, $\phi 2.6 \times 5\text{mm}$			
231		22708096	Screw, $\phi 2.6 \times 12\text{mm}$			
232	4-G	22701338	Screw, $\phi 2.6 \times 8\text{mm}$			
233	4-F	22707350	Screw, $\phi 2.6 \times 5\text{mm}$			
234	3-E	22708528	Screw, $\phi 2.6 \times 3\text{mm}$			
235	3-C	22701361	Screw, $\phi 2.6 \times 5\text{mm}$			
236	4-C	22701467	Screw, $\phi 2 \times 3\text{mm}$			
237	3-C	22708542	Screw, $\phi 3 \times 8\text{mm}$			
238	2-E	20743183	Upport, Chassis			
240	3-E	25779512	Drive, Spring			
241	3-G	22180313	Jump-Wire (100)			
242	2-F	22180314	Jump-Wire (200)			

# Packing Assembly Parts List

NOTE: The parts without part numbers are not supplied.

Symbol No.	Part No.	Description
101	22925580	Carton, Box
102	22936373	Cushion, L
103	22936374	Cushion, R
104	22941302	Poly, Bag
105	22101314	Battery, R6-E
106	22120119	Remote Control (LUX)
107	22164775	JNT, Cord/TSC
108	22197012	Assembly, Cord Plug
● 109	68P81707F05	Owners Manual
▲ 109	68P81707F03	Owners Manual
■ 109	68P81707F02	Owners Manual

Symbol No.	Part No.	Description

Note: ● : For North American model only (UC)  
 ▲ : For Canadian model only (UQ)  
 ■ : For General Foreign model only (EK)  
 Others : Common

## Packing Method View

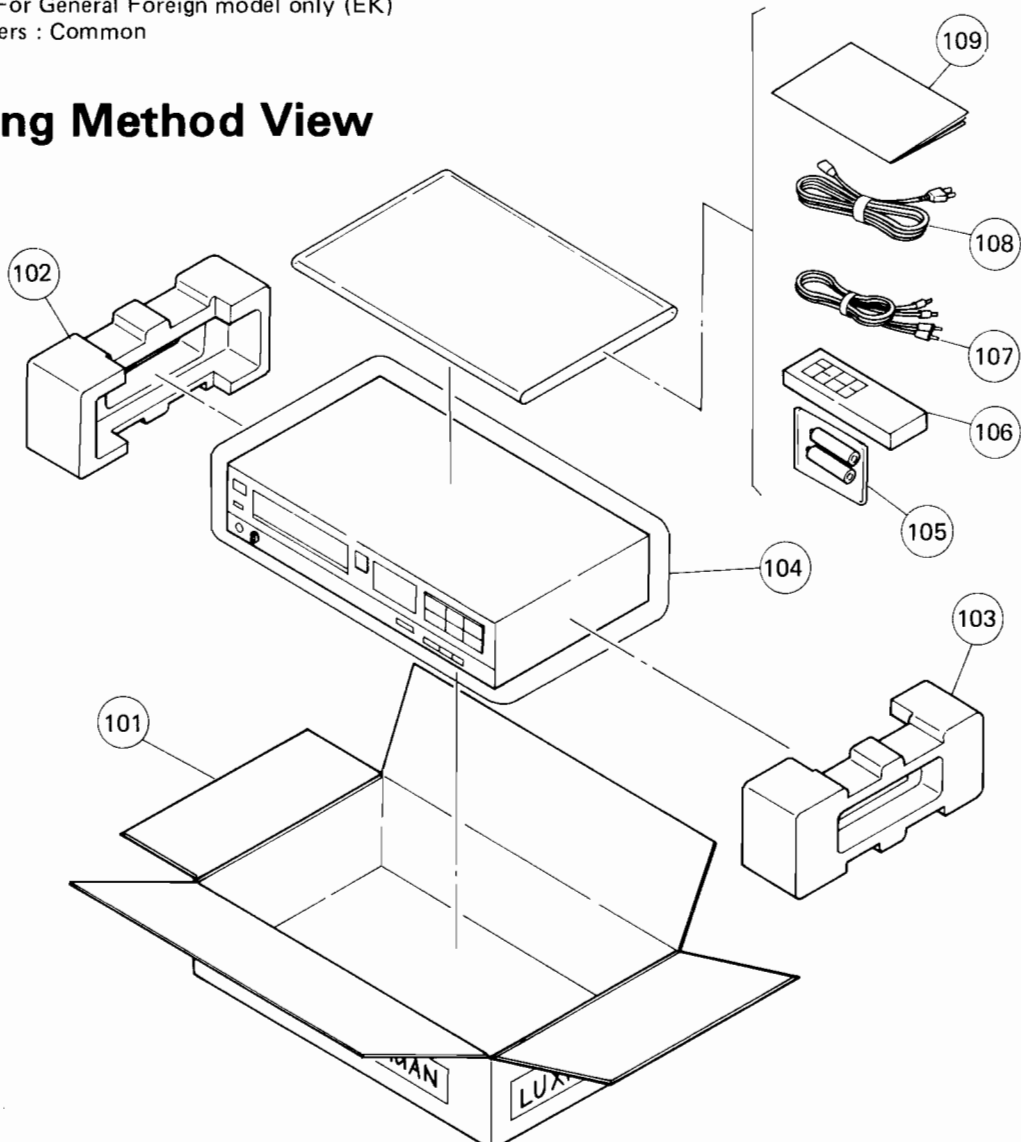

# Semi-Conductor Lead Identifications

**NJM2904D: Q102, 312**

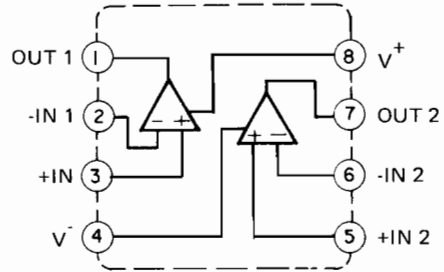
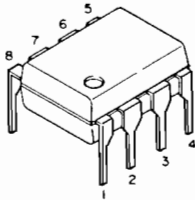

**TA7354P: Q301**

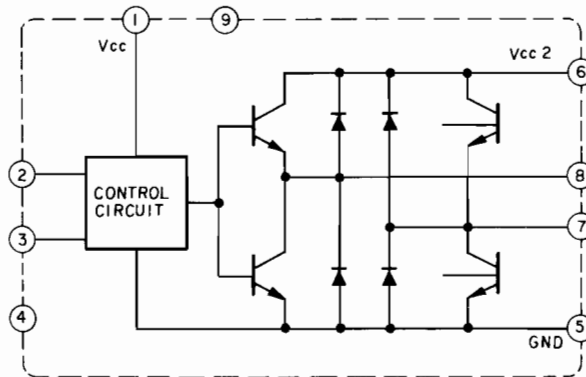
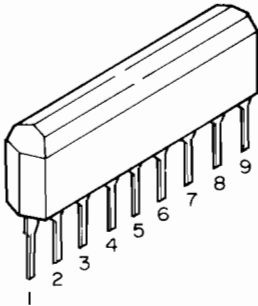

**TC9200F: Q306**

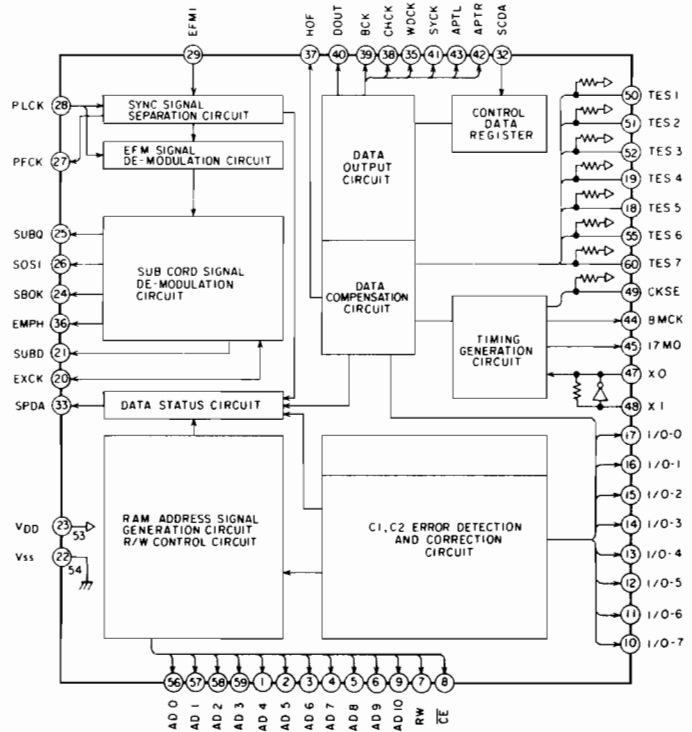
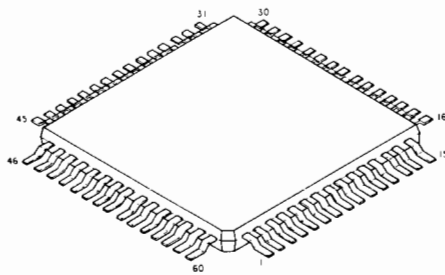

TC9201F: Q307

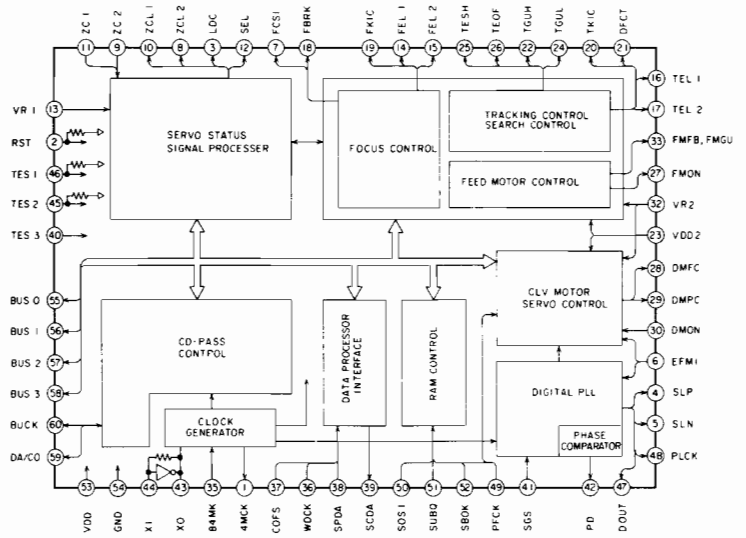
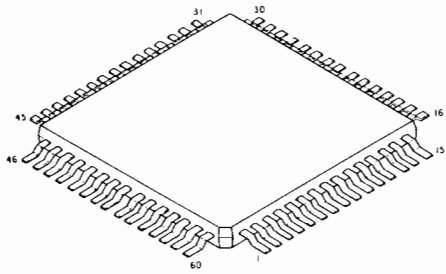

TA8101N: Q309

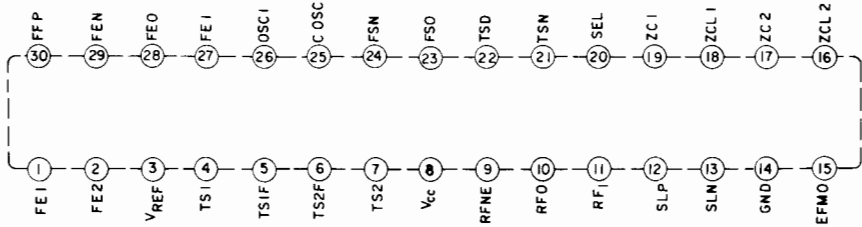
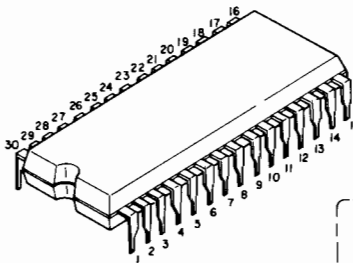

NJM3403AD: Q310

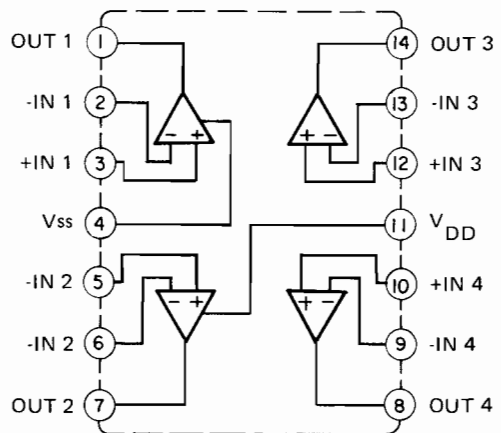
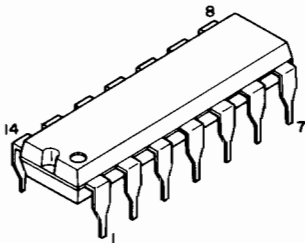



TC4053BP: Q313

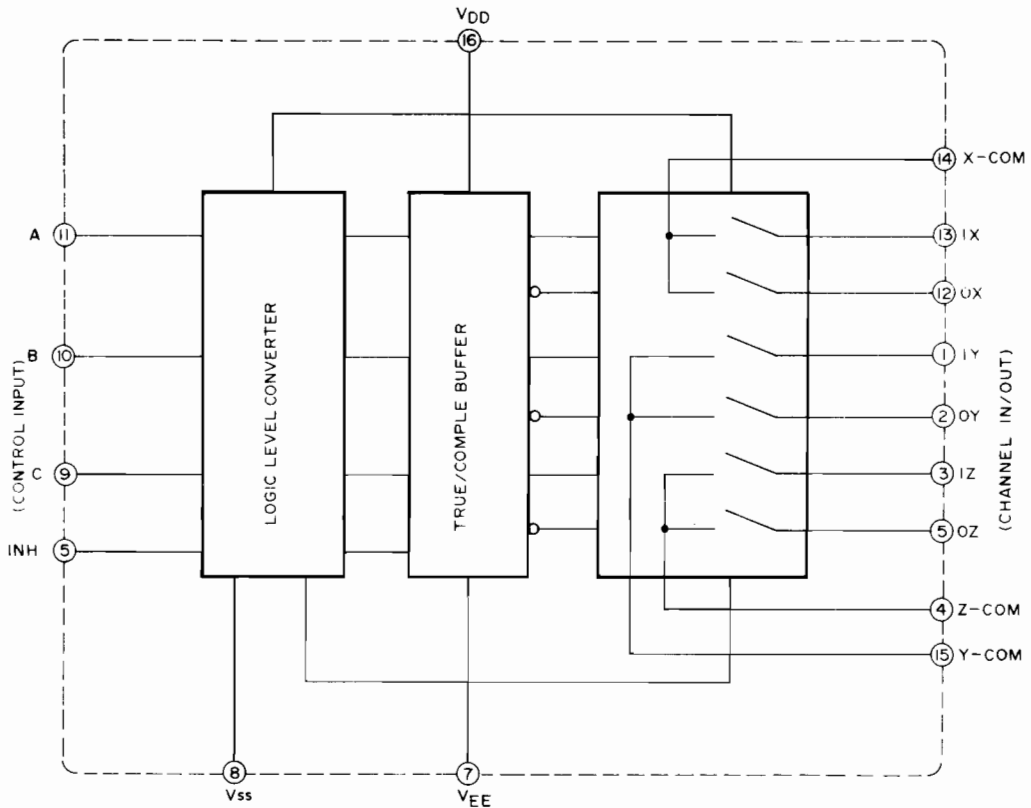
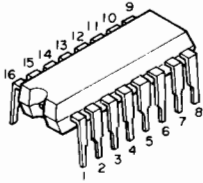

TA8102P: Q314, 315, 316, 317

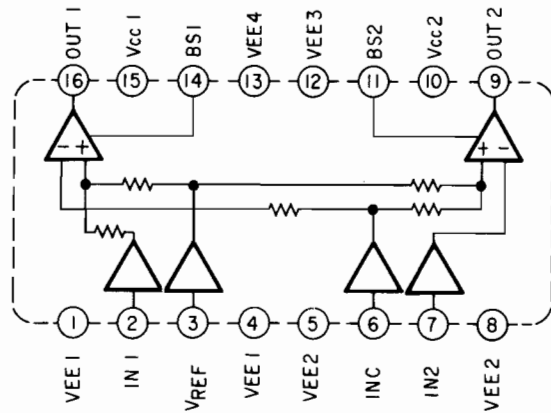
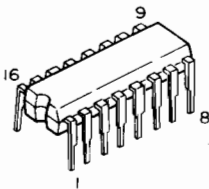

TD6709N: Q501

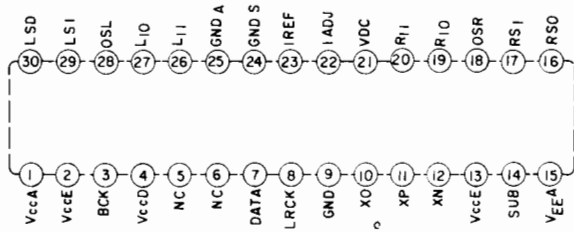
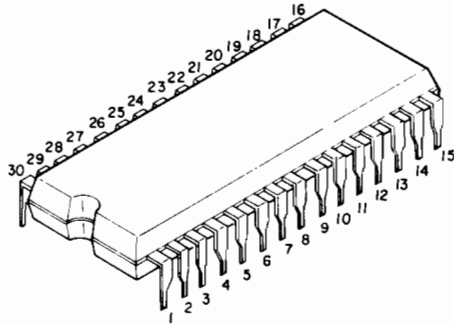

TD6102P: Q502

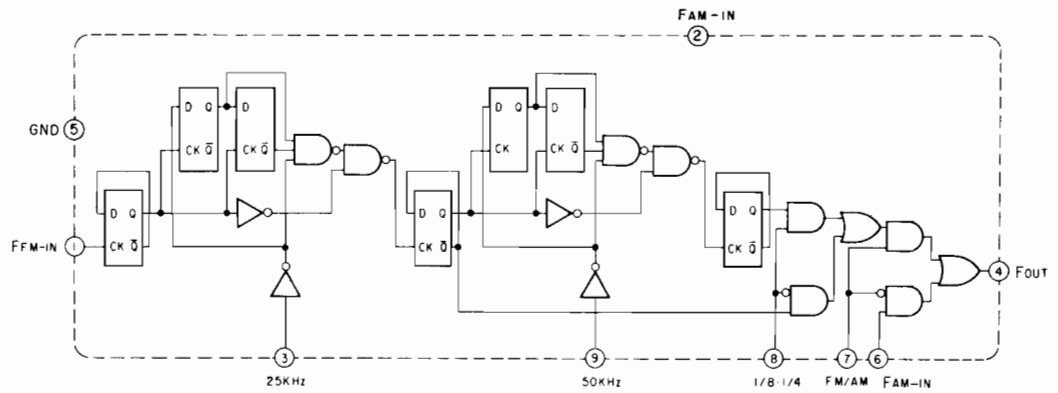
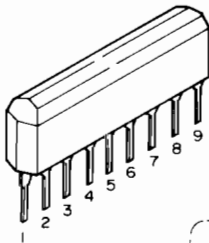

NJM4560DX: Q503

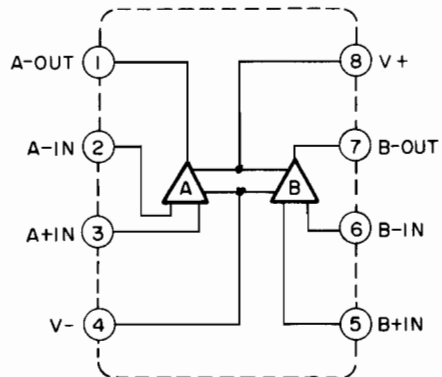
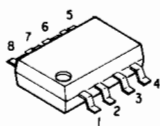

**NJM79L08A: Q553**

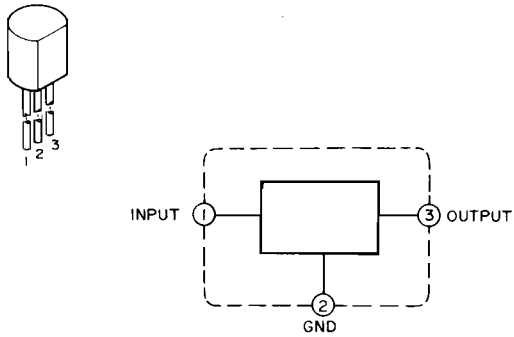

**TA78L008AP: Q554**

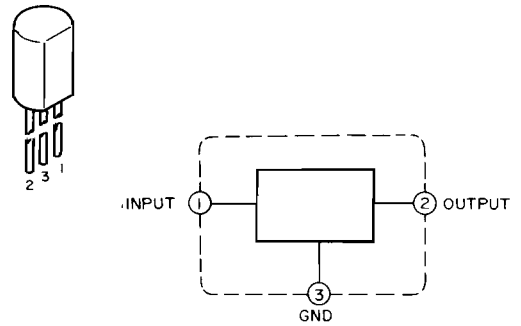

**NJM4556S: Q701**

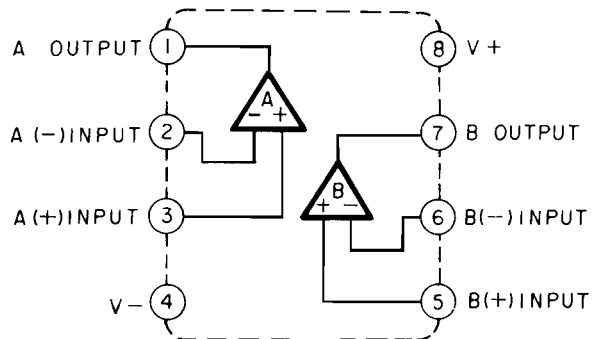
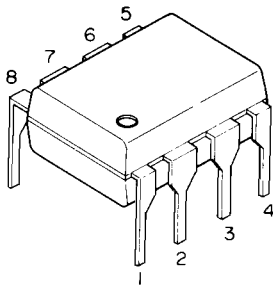

**2SC2236: Q101**  
**2SA966: Q906, 910**

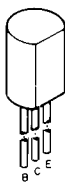

**2SA1015: Q203, 601, 602, 603, 604**  
**2SC2878: Q311, 507, 508, 902**



**2SC2458: Q204, 302, 318**  
**2SA1048: Q506, 901**



**2SK365: Q504, 505, 903, 905, 907, 909**



**2SD1413: Q904, 908, 911**

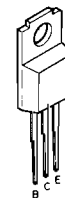

# Schematic Diagram

IC	1: Q102	2: Q312	3: Q310	Q307
	Q202	Q301 Q303	Q314 ~ Q317	Q201
Transistor(Q)	Q203	Q101	Q302	Q311 Q318
	Q204	Q601 Q602 Q603 Q604	Q903 ~ Q911	
Diode (D)	D101	D102	D302 D303	D301
	D205	D213	D214	D203 D206 ~ D212
		D204 D201 D202	D904 ~ D907	D914 D908 D909 ~

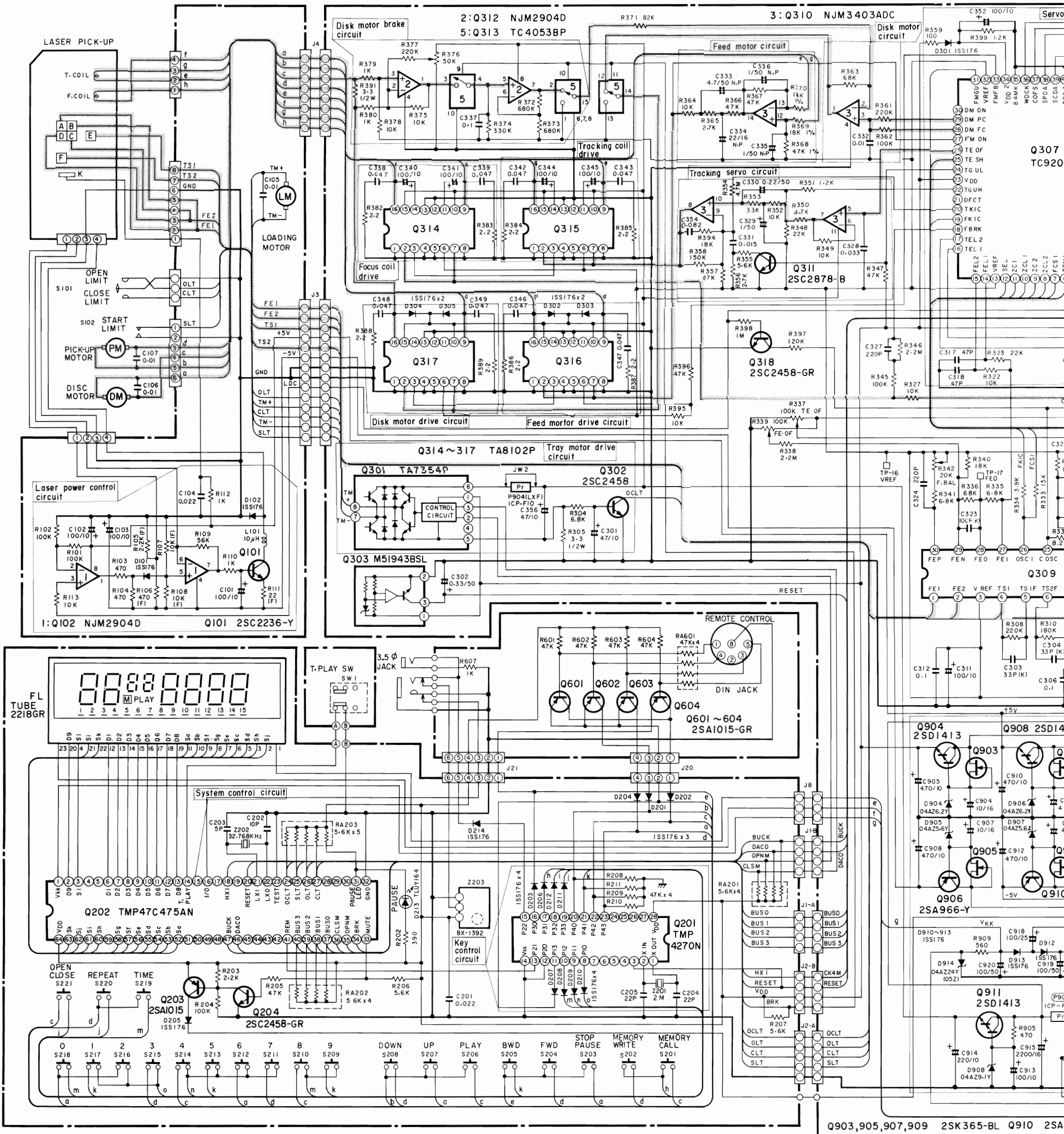

Q307	Q309	Q306	Q502	Q308	Q551	Q1			
Q903 ~ Q911		Q902	Q901	Q506	Q504	Q505	Q507	Q508	Q1
D904 ~ D907		D306	D902	D903	D901	D915	D1 ~ D4		D1
D914		D908	D909 ~ D913						

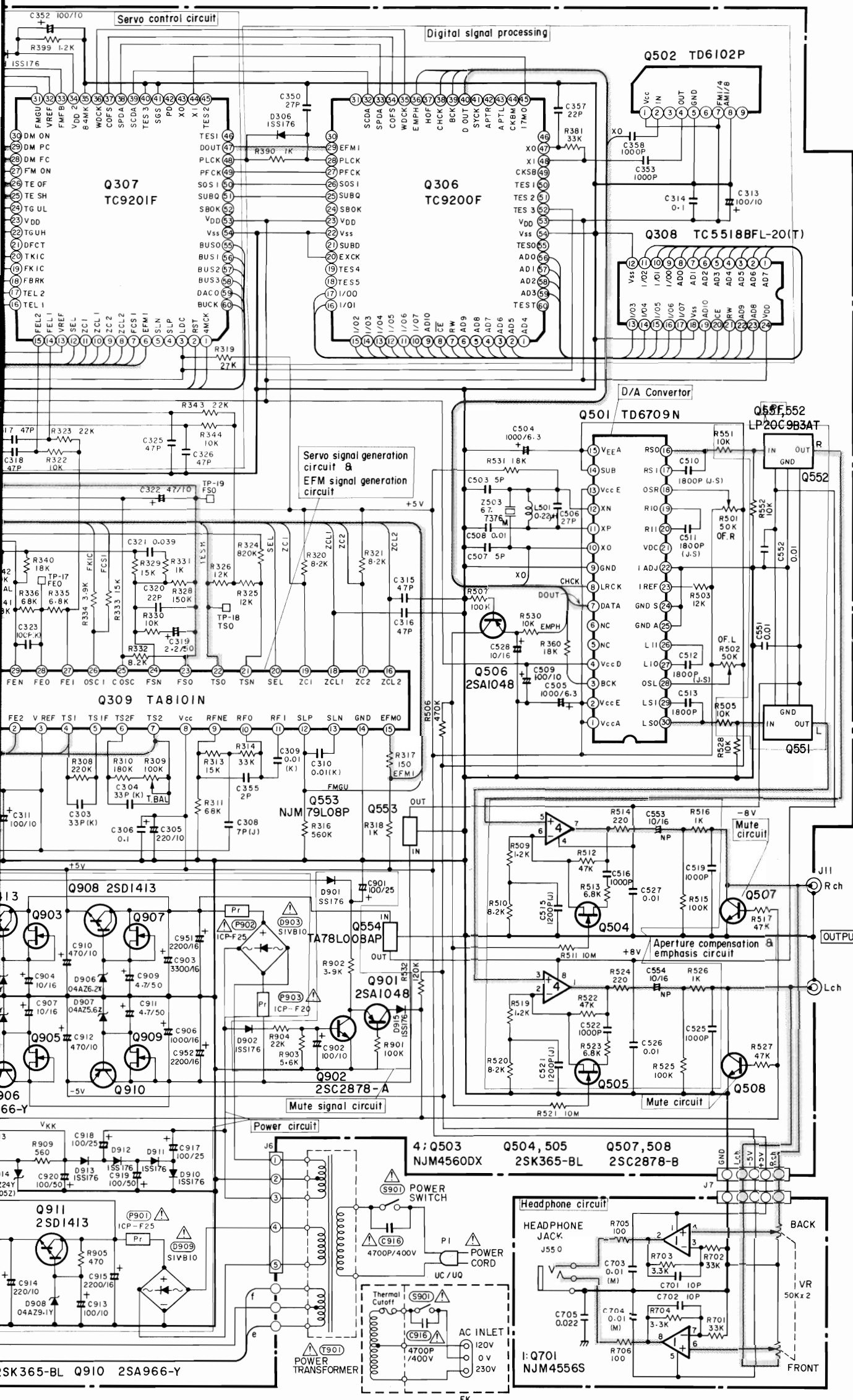

### Wireless Remocon Unit

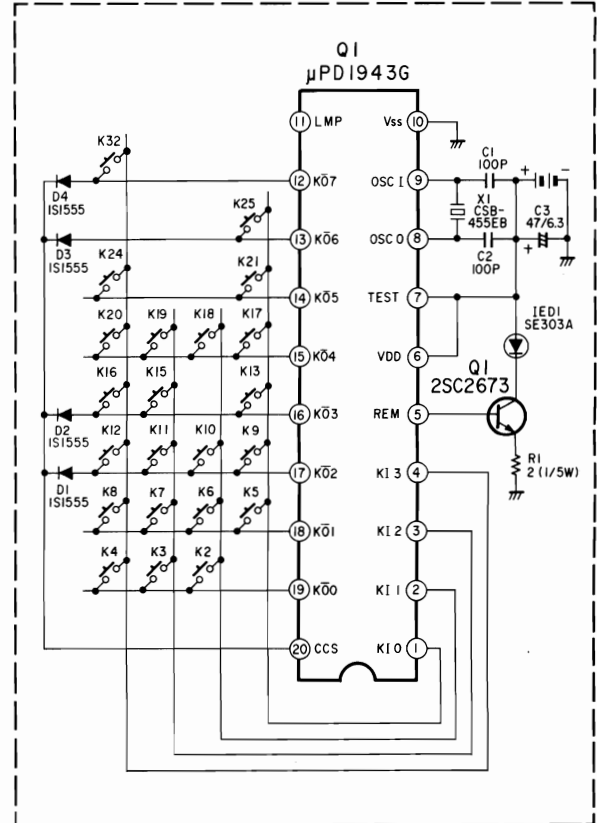

### NOTES:

- All resistance values are in ohms. K = 1,000
- All capacitance values are in microfarads. P = 1,000,000